

wooke
ROCK DRILL EQUIPMENT
五环欧科

威猛6系高频快冲
DTH HAMMER WOOKE 6 SERIES

全球最快 · 软硬通吃



C目录
ONTENT

企业简介 Company Profile	-----	1
钻头尾柄说明 Bit Shank Identification Chart	-----	3
旋风快冲XF-90	-----	7
XF-90K	-----	8
威猛快冲WOOKE25	-----	9
WOOKE30	-----	10
WOOKE46	-----	11
WOOKE56	-----	12
WOOKE66	-----	13
WOOKE86	-----	14
WOOKE100	-----	15

企业简介

COMPANY INTRODUCTION

五环钻机具有限责任公司创立于1995年，位于世界水电名都——宜昌。是一家经三峡工程打造，引领行业发展的创新型企业，是国家高新技术企业、湖北省隐形冠军企业、中国钎钢钎具协会常务理事单位。

公司专注于制造高压潜孔冲击器、钻头、钻杆；顶锤式螺纹钻头、钎尾、连接套；反循环式潜孔冲击器、钻头；各类偏心、同心跟管钻具。应用于露天石场、采矿、水利水电、地质勘探等工程领域。

“专注品质，追求卓越”。公司拥有多项颠覆性专利和高压潜孔钻具制造技术；独创旋风、威猛系列潜孔冲击器，领先全国及世界，并成功实现了产品转型升级、传统生产向智能化生产的跨越。综合实力处于国内行业领先地位。

Established in 1995, Wooke Rock Drill Equipment Co Ltd is located in the city of Yichang, known for the worldwide famous hydroelectric project “Three Gorges Dam”. With the products testified by Three Gorges Project, we are an innovative enterprise pioneering the industry development. Our company has been awarded as “National High-Tech Enterprise”, “State Invisible Enterprise Champion”, and is a current “Executive Member of China Rock-Drill Steel and Tools Association”.

Our company focuses on manufacturing high air pressure DTH hammers, bits, drill pipes, top hammer threaded button bits, shank adapters, coupling sleeves, RC hammers and bits, and a variety of eccentric and symmetric casing systems, which are widely used in open-pit quarry, mining, water and hydropower projects, geological exploration etc.

“Focus on quality, strive for excellence” is our motto. Our company has a number of disruptive product patents and intellectual properties in high air pressure DTH rock drilling tools manufacturing technologies. We have exclusively designed and launched TND series、Wooke series DTH products, both are cutting-edge domestically and internationally, and have successfully transformed from traditional production to intelligentized automatic production. Our comprehensive competitiveness is ranking among the leading positions in China.





▲ 技术研发中心
Technology research and Development Center



▲ 意大利吉埃斐公司生产热处理生产线
Italy Ji Aifei produced heat treatment production line





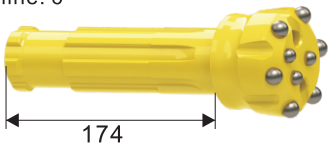
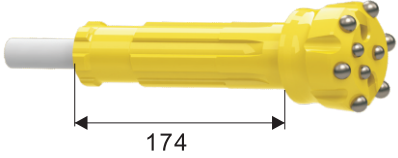
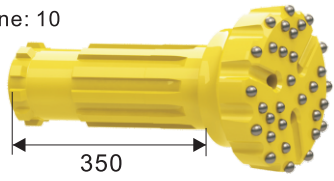
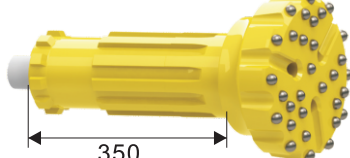
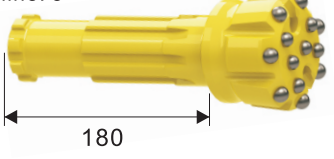
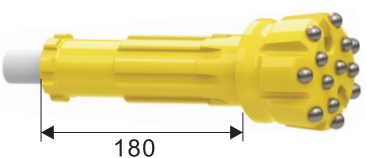
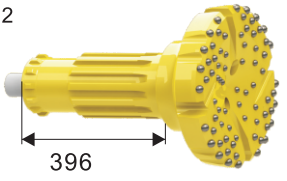
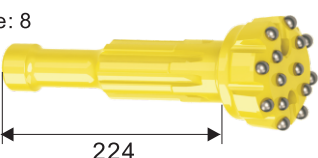
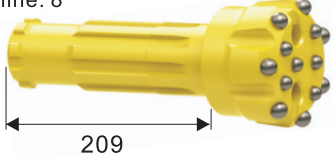
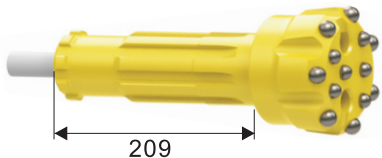
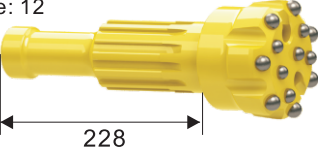
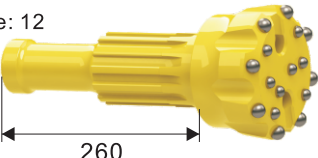
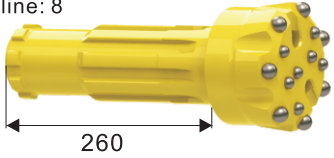
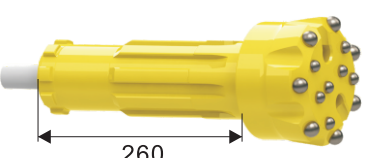
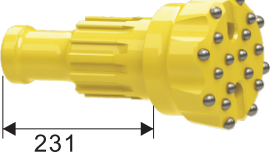
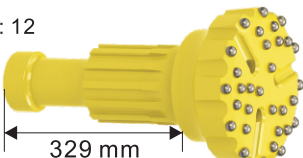
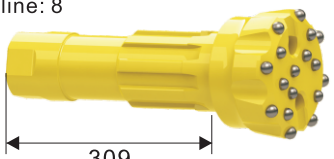
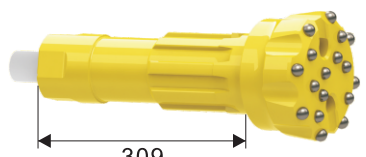
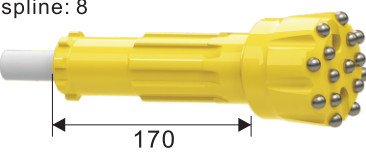
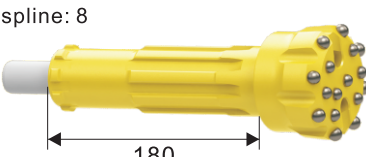

▲ 现代高档数控生产线(金加工)
Modern CNC production lines (metal processing)



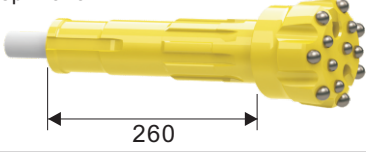
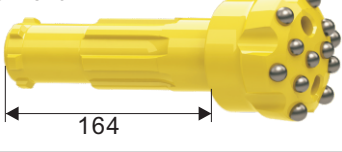
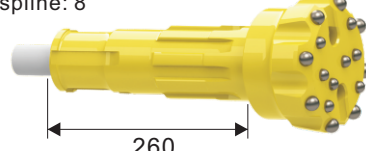
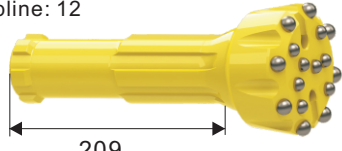
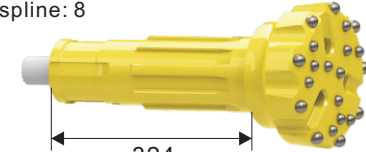
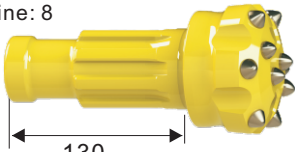
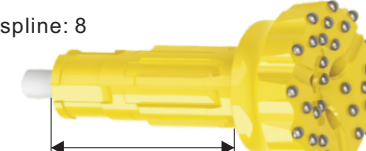
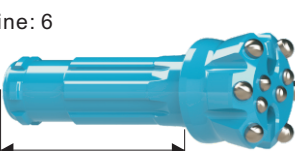

<p>花键数spline: 6</p>  <p>2.5N 174</p>  <p>CWG76 174</p>	<p>花键数spline: 10</p>  <p>380N 350</p>  <p>DHD380 350</p>
<p>花键数spline: 8</p>  <p>3.5N 180</p>  <p>DHD3.5 180</p>	<p>花键数spline: 12</p>  <p>DHD110 396</p> <p>花键数spline: 8</p>  <p>Mission 30 224</p>
<p>花键数spline: 8</p>  <p>340N 209</p>  <p>DHD340A,IR4, Secoroc COP44 209</p>	<p>花键数spline: 12</p>  <p>Mission 40 228</p> <p>花键数spline: 12</p>  <p>Mission 50 260</p>
<p>花键数spline: 8</p>  <p>350N 260</p>  <p>DHD350R Secoroc COP54 260</p>	<p>花键数spline: 12</p>  <p>Mission 60 60W 65 231</p> <p>花键数spline: 12</p>  <p>Mission 80 329 mm</p>
<p>花键数spline: 8</p>  <p>360N 309</p>  <p>DHD360,IR SF6, Secoroc COP64 309</p>	<p>花键数spline: 8</p>  <p>Mach33 170</p> <p>花键数spline: 8</p>  <p>Mach44 180</p>

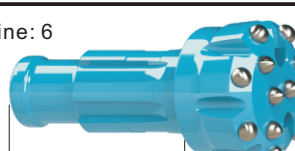
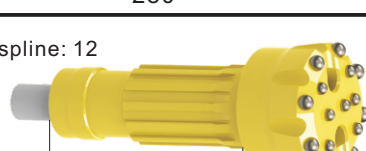
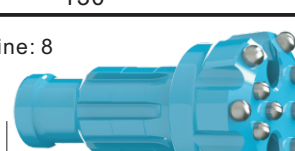
钻头尾柄说明

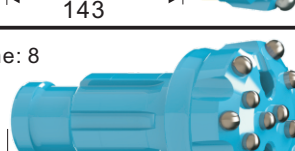
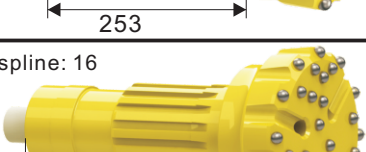
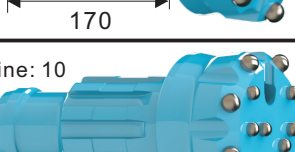
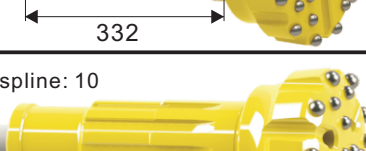
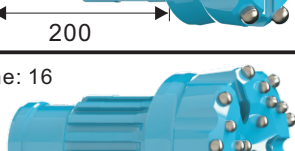
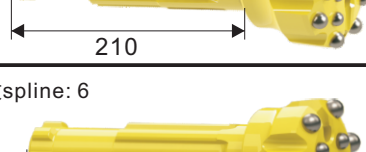
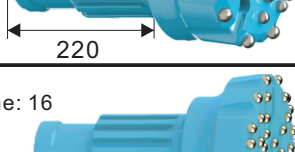
Bit Shank Identification Chart

<p>花键数spline: 8</p>  <p>SD4</p> <p>260</p>	<p>花键数spline: 6</p>  <p>BR3</p> <p>164</p>
<p>花键数spline: 8</p>  <p>SD5</p> <p>260</p>	<p>花键数spline: 12</p>  <p>BR4</p> <p>209</p>
<p>花键数spline: 8</p>  <p>SD6</p> <p>324</p>	<p>花键数spline: 8</p>  <p>XF90K</p> <p>130</p>
<p>花键数spline: 8</p>  <p>SD8</p> <p>321</p>	<p>花键数spline: 6</p>  <p>Wooke25</p> <p>141</p>
<p>花键数spline: 10</p>  <p>QL40</p> <p>280</p>	<p>花键数spline: 6</p>  <p>Wooke30</p> <p>130</p>
<p>花键数spline: 12</p>  <p>QL50</p> <p>240</p>	<p>花键数spline: 8</p>  <p>Wooke46</p> <p>143</p>
<p>花键数spline: 12</p>  <p>QL60</p> <p>253</p>	<p>花键数spline: 8</p>  <p>Wooke56</p> <p>170</p>
<p>花键数spline: 16</p>  <p>QL80</p> <p>332</p>	<p>花键数spline: 10</p>  <p>Wooke66</p> <p>200</p>
<p>花键数spline: 10</p>  <p>MD4</p> <p>210</p>	<p>花键数spline: 16</p>  <p>Wooke86</p> <p>220</p>
<p>花键数spline: 6</p>  <p>BR2</p> <p>165</p>	<p>花键数spline: 16</p>  <p>Wooke100</p> <p>280</p>

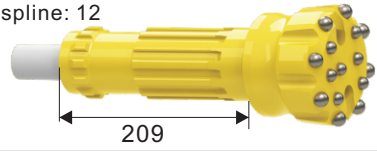
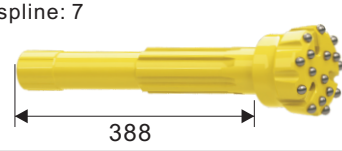
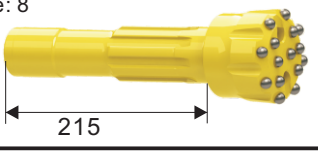
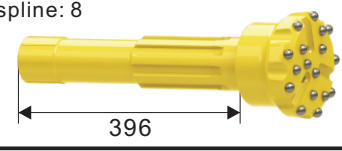
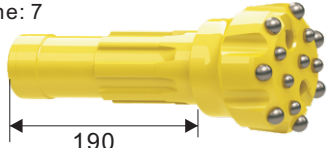
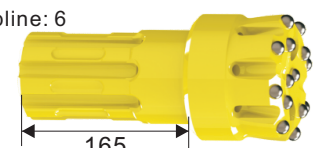
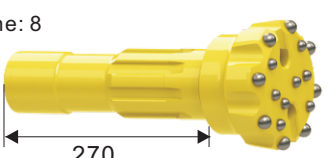
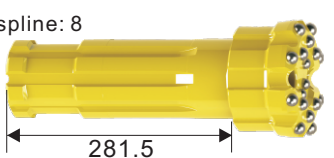
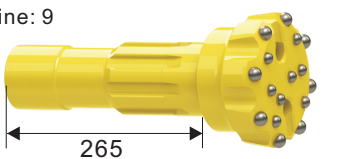
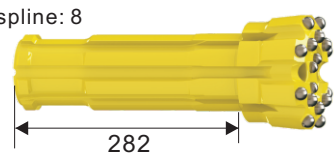
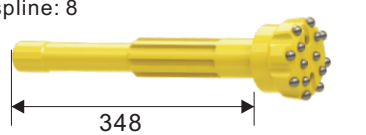
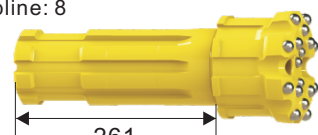
花键数spline: 8  245 COP34	花键数spline: 8  384 COPROD89
花键数spline: 12  209 TD40	花键数spline: 7  388 COPROD102
花键数spline: 8  215 COP32	花键数spline: 8  396 COPROD127
花键数spline: 7  190 COP42	花键数spline: 6  165 FZT140
花键数spline: 8  270 COP52	花键数spline: 8  281.5 RE054
花键数spline: 9  265 COP62	花键数spline: 8  282 DR53
花键数spline: 8  348 COPROD76	花键数spline: 8  261 PR54R

钻头头部形状与选型 Bit head design and selection



平面球齿型
Flat front
Spherical

适用钻凿硬岩，坚硬岩石及磨蚀性强岩层。
Applications:
For drilling in hard and abrasive rock.



平面边球中尖型
Flat front
Spherical+Ballistic

适用钻凿中硬岩，硬岩及中等磨蚀性岩石。
Applications:
For drilling in medium-hard to hard and moderately abrasive rock.



凸面边球中尖型
Convex front
Spherical+Ballistic

适用中硬岩及磨蚀性中等岩层。
Applications:
For drilling in medium-hard and moderately abrasive rock.



凸面全尖型
Convex front
Ballistic

适用非磨蚀性岩层的高速钻凿。
Applications:
For drilling at high penetration rates in non abrasive rock.



凹面球齿型
Concave front
Spherical

适用中硬岩，并有很小钻孔偏差。
Applications:
For drilling in medium-hard, minimum hole deviation control.

6系威猛高频快冲
WOOKE Series 6 High frequency Hammer

赚钱新利器 Meter Saver



——最牛钻具来了 Eye-catching hammer is coming

五环欧科"6"系威猛高频潜孔冲击器(发明专利)是凿岩最新利器,速度更快,耗风更低,寿命更长,更稳定。更为突出的是"软岩"“硬岩”都能保持最快穿孔速度。

Wooke Series 6 high-frequency hammer (patented) is the money-saver for the new drilling era, with outstanding features in air-saving, penetration, longevity and reliability. Excellent performance in both "soft" ground and "hard formation" in terms of ROP.



亮点 Highlights

赚钱: Cost saving

软、硬岩石每班多打孔1-2个
Proved 1-2 more holes/shift

省油: Fuel saving

同比空气压力升高, 转速下降
Higher air pressure held under same air supplied,
Less air consumption

保压: Air pressure holding

钻凿全过程压力恒定
Constant air maintained during entire drilling life

耐用: Longevity

软、硬岩单套累计钻凿4000-15000米
Generally 4000 - 15000 meters depending on soft
or hard ground

旋风快冲XF-90[®]

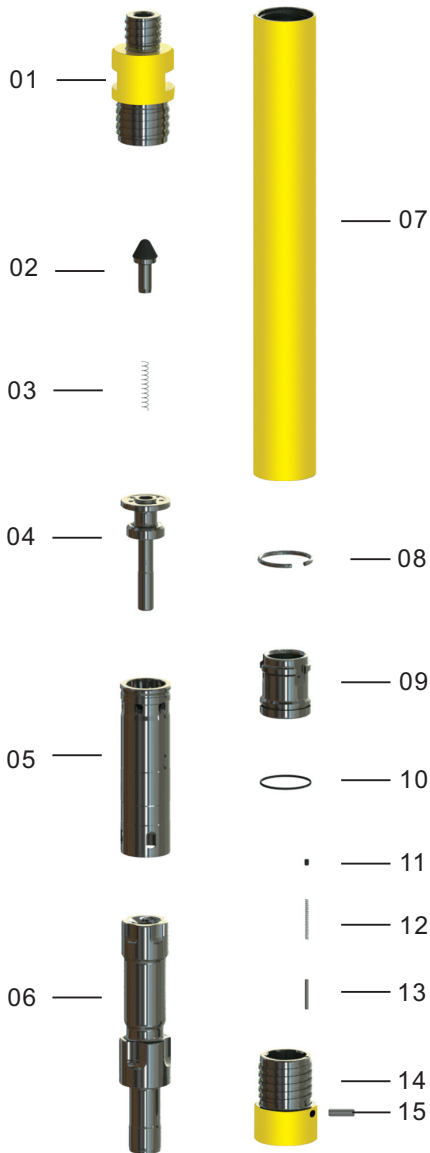

部件Replacement Parts	单重Weight(kg)	件号Part No.
01 后接头 Top Sub:T48X10X2	3.52	XF-HJT-XF90
02 逆止阀 Check Valve Dart	0.02	XF-NZF-90
03 弹簧 Spring	0.02	TH-90
04 配气杆 Rigid Valve	0.66	XF-PQG-90
05 内缸 Internal Cylinder	1.02	XF-NG-90
06 活塞 Piston	4.59	XF-HS-90
07 外套管 Piston Case	6.43	XF-WTG-90
08 卡簧 Jump Ring	0.04	XF-JR-90
09 导向套 Guide Sleeve	0.87	XF-DXT-90
10 O型圈 O-Ring	0.01	O-DXT-90
11 橡胶塞 Rubber stopper	0.01	XF-XJS-90
12 弹簧 Spring	0.01	XF-KH-XF90
13 直销 Direct	0.01	XF-ZZ-XF90
14 前接头 Driver Sub	1.68	XF-QJT-XF90
15 横销 Cross pin	0.02	XF-ZX-XF90
密封件 Seal Kit 10 × 1	0.01	SK-XF90
易耗件 Consumable	11.64	CSB-XF90
01 × 1		
07 × 1		
14 × 1		
密封件 Seal Kit		

钻头尾柄 Bit shank
CIR90

钻头直径 Bit dia
90; 100; 110

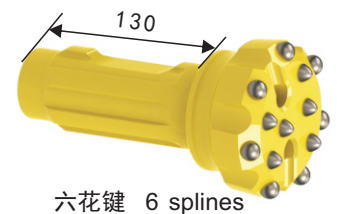

六花键 6 splines

重量Weight (kg)	外径Outside diameter (mm)	冲击器有效长度Hammer length without bit (mm)	
19	80	725	
钻孔范围Hole Range	适用气压Work Pressure	耗气量Air consumption, m ³ /min	
mm	bar	6bar	12bar
Φ90-Φ110	6-12	7.2	12

无尾管中气压潜孔冲击器

Medium High Air Pressure DTH Hammers

wooke
ROCK DRILL EQUIPMENT
五环欧科

旋风快冲XF-90K[®]

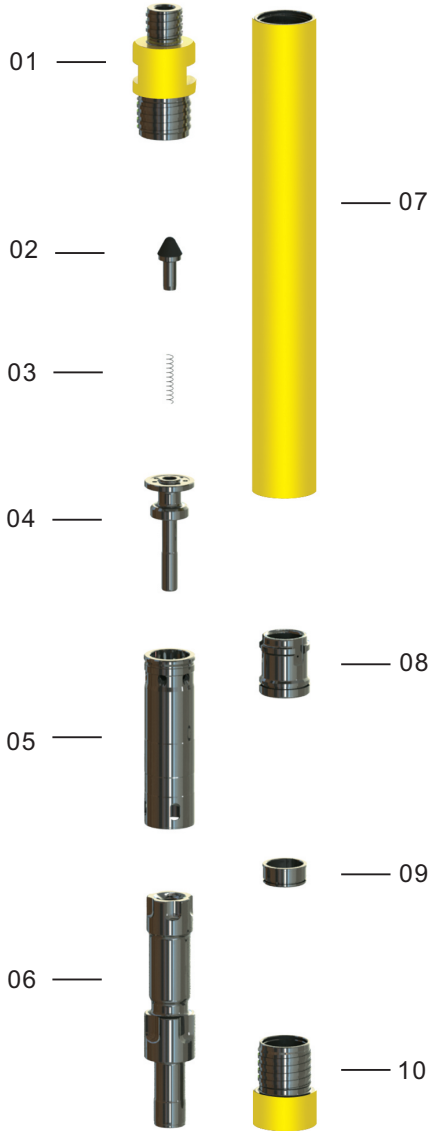

部件Replacement Parts	单重Weight(kg)	件号Part No.
01 后接头 Top Sub:T48X10X2	3.52	XF-HJT-XF90K
02 逆止阀 Check Valve Dart	0.02	XF-NZF-90
03 弹簧 Spring	0.02	TH-90
04 配气杆 Rigid Valve	0.66	XF-PQG-90
05 内缸 Internal Cylinder	1.02	XF-NG-90
06 活塞 Piston	4.59	XF-HS-90
07 外套管 Piston Case	6.43	XF-WTG-90
08 导向套 Guide Sleeve	0.87	XF-DXT-90
09 卡环 Bit Retainer Ring	0.16	WK-KH-90
10 前接头 Driver Sub	1.68	XF-QJT-XF90K
易耗件 Consumable	11.63	CSB-XF90K
01 × 1		
07 × 1		
10 × 1		
钻头尾柄 Bit shank XF90K		
钻头直径 Bit dia 90; 95; 100		
<p>八花键 8 splines</p>		

重量Weight (kg)	外径Outside diameter (mm)	冲击器有效长度Hammer length without bit (mm)	
19	80	725	
钻孔范围Hole Range	适用气压Work Pressure	耗气量Air consumption, m ³ /min	
mm	bar	6bar	12bar
Φ90-Φ100	6-12	7.2	12

威猛快冲Wooke25[®]

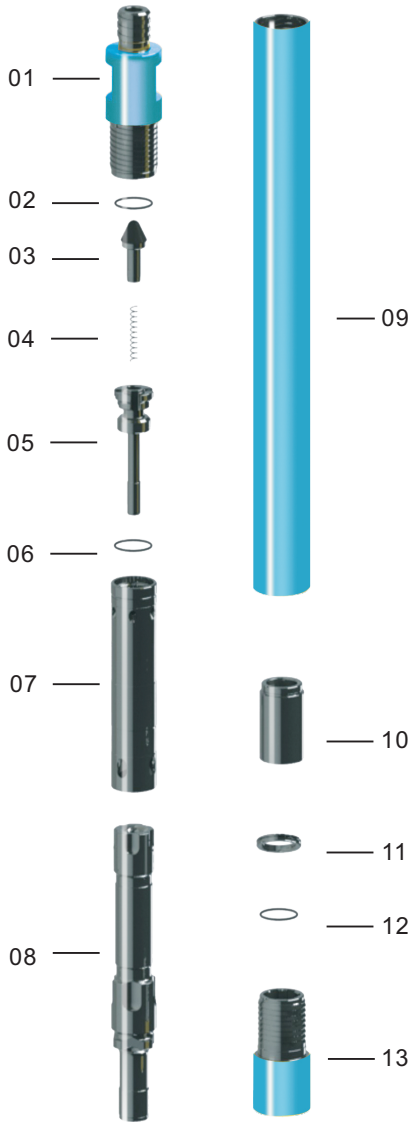

部件Replacement Parts	单重Weight(kg)	件号Part No.
01 后接头 T42X10X2	3.34	TND-HJT-25
02 O型圈 O-Ring	0.01	O-HJT-25
03 逆止阀 Check Valve Dart	0.10	TND-NZF-2.5
04 弹簧 Spring	0.02	TH-2.5
05 配气杆 Rigid Valve	0.45	TND-PQG-25
06 O型圈 O-Ring	0.01	O-PQG-25
07 内缸 Internal Cylinder	0.97	TND-NG-25
08 活塞 Piston	4.00	TND-HS-25
09 外套管 Piston Case	5.96	TND-WTG-25
10 导向套 Guide Sleeve	0.55	TND-DXT-25
11 卡环 Bit Retainer Ring	0.06	TND-KH-25
12 O型圈 O-Ring	0.01	O-KH-25
13 前接头 Driver Sub	1.74	TND-QJT-25
密封件 Seal Kit	0.03	SK-25
02 × 1		
06 × 1		
12 × 1		
易耗件 Consumable	11.07	CSB-25
01 × 1		
07 × 1		
11 × 1		
密封件 Seal Kit		
钻头尾柄 Bit shank Wooke25 [®]		
钻头直径 Bit dia 78;82		

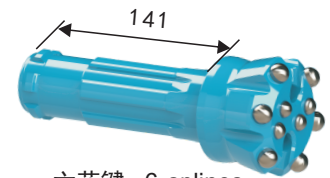

重量Weight (kg)	外径Outside diameter (mm)	冲击器有效长度Hammer length without bit (mm)	
17.5	70	765	
钻孔范围Hole Range	适用气压Work Pressure	耗气量Air consumption, m ³ /min	
mm	bar	6bar	12bar
Φ78-Φ82	8-18	2	4

无尾管中高气压潜孔冲击器 Medium High Air Pressure DTH Hammers

wooke
ROCK DRILL EQUIPMENT
五环欧科

威猛快冲Wooke30[®]

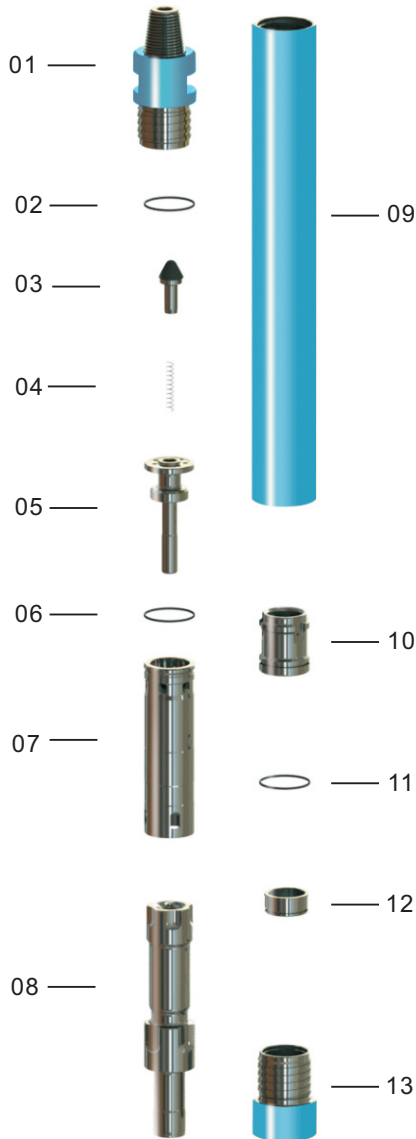

部件Replacement Parts	单重Weight(kg)	件号Part No.
01 后接头 Top Sub:2 $\frac{3}{8}$ "API REG	3.52	WK-HJT-30
02 O型圈 O-Ring	0.01	O-BCT-30
03 逆止阀 Check Valve Dart	0.02	TND-NZF-3.5
04 弹簧 Spring	0.02	TH-3.5
05 配气杆 Rigid Valve	0.66	WK-PQG-30
06 O型圈 O-Ring	0.01	O-BCT-30
07 内缸 Internal Cylinder	1.02	WK-NG-30
08 活塞 Piston	4.59	WK-HS-30
09 外套管 Piston Case	6.43	WK-WTG-30
10 保持套 Retainer Sleeve	0.87	WK-BCT-30
11 O型圈 O-Ring	0.01	O-BCT-30
12 卡环 Bit Retainer Ring	0.16	WK-KH-30
13 前接头 Driver Sub	1.68	WK-QJT-30
密封件 Seal Kit	0.03	SK-30
02 × 1		
06 × 1		
11 × 1		
易耗件 Consumable	11.66	CSB-30
01 × 1		
07 × 1		
11 × 1		
密封件 Seal Kit		

钻头尾柄 Bit shank
Wooke30[®]

钻头直径 Bit dia
90; 95; 100

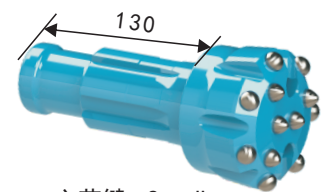

六花键 6 splines

重量Weight (kg)	外径Outside diameter (mm)	冲击器有效长度Hammer length without bit (mm)	
19	80	725	
钻孔范围Hole Range	适用气压Work Pressure	耗气量Air consumption, m ³ /min	
mm	bar	6bar	12bar
Φ90-Φ110	10-18	3.5	8

威猛快冲Wooke46®

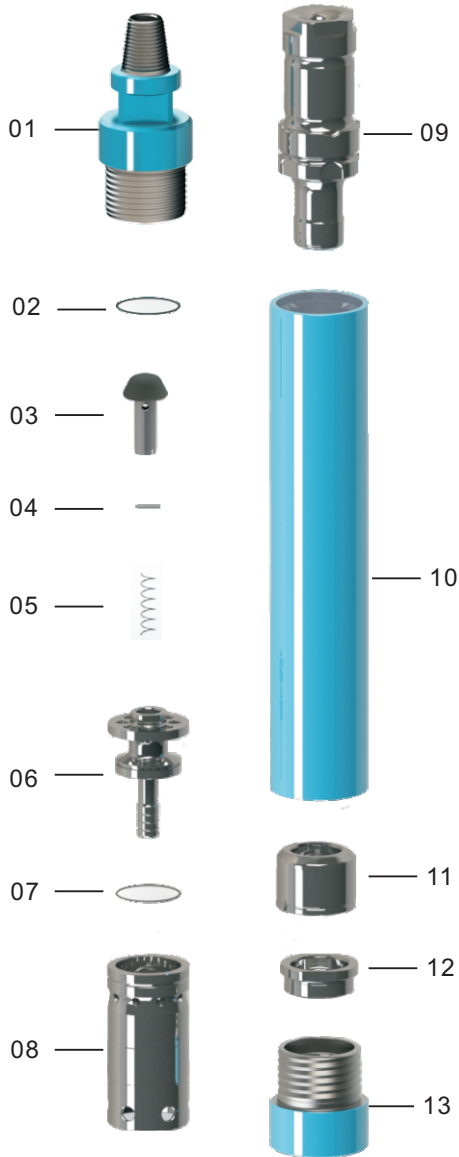

部件Replacement Parts	单重Weight(kg)	件号Part No.
01 后接头 Top Sub:2 ^{3/8} "API REG	6.67	WK-HJT-46
02 O型圈 O-Ring	0.01	O-HJT-46
03 逆止阀 Check Valve Dart	0.15	TND-NZF-4/5
04 调气塞 Choke Blank (备选) (Optional)	0.01	TND-TQS-4/5
05 弹簧 Spring	0.02	TH-4/5
06 配气杆 Rigid Valve	1.70	WK-PQG-46
07 O型圈 O-Ring	0.01	O-PQG-46
08 内缸 Internal Cylinder	1.54	WK-NG-46
09 活塞 Piston	7.85	WK-HS-46
10 外套管 Piston Case	9.31	WK-WTG-46
11 导向套 Guide Sleeve	1.31	WK-DXT-46
12 卡环 Bit Retainer Ring	0.68	WK-KH-46
13 前接头 Driver Sub	3.45	WK-QJT-46
密封件 Seal Kit	0.02	SK-46
02 × 1		
07 × 1		
易耗件 Consumable	19.45	CSB-46
01 × 1		
10 × 1		
13 × 1		
密封件 Seal Kit		

钻头尾柄 Bit shank
Wooke46®

钻头直径 Bit dia
115;120;127;130

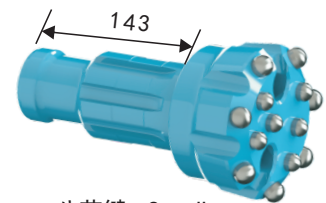

八花键 8 splines

重量Weight (kg)	外径Outside diameter (mm)	冲击器有效长度Hammer length without bit (mm)		
33	101	764		
钻孔范围Hole Range	适用气压Work Pressure	耗气量Air consumption, m ³ /min		
mm	bar	10bar	18bar	24bar
Φ110-Φ130	10-25	4.5	9	14

无尾管中高气压潜孔冲击器 Medium High Air Pressure DTH Hammers

wooke
ROCK DRILL EQUIPMENT
五环欧科

威猛快冲Wooke56®

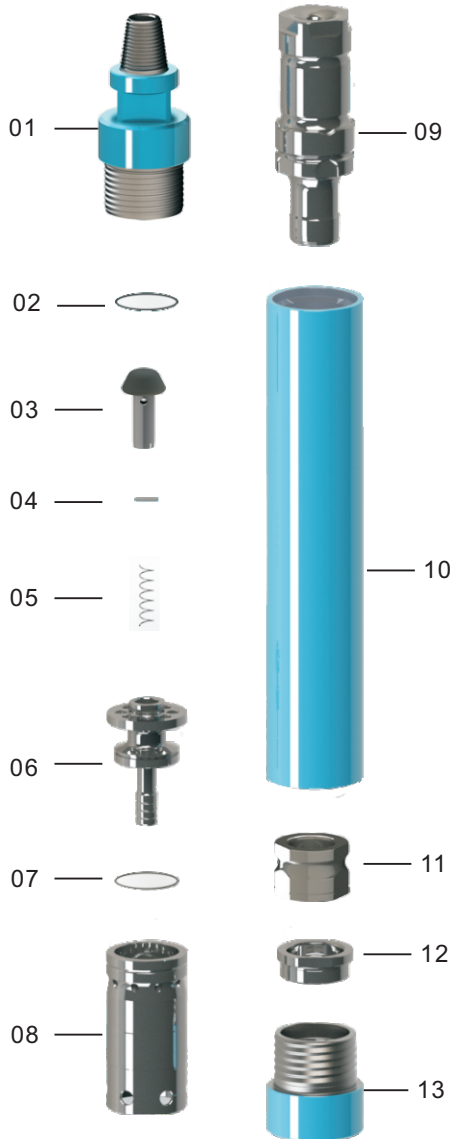

部件Replacement Parts	单重Weight(kg)	件号Part No.
01 后接头 Top Sub:2 ³ / ₈ "API REG	10.0	WK-HJT-56
3 ¹ / ₂ "API REG	10.5	WK-HJT-56A *
02 O型圈 O-Ring	0.01	O-HJT-56
03 逆止阀 Check Valve Dart	0.16	TND-NZF-4/5
04 调气塞 Choke Blank (备选) (Optional)	0.01	TND-TQS-4/5
05 弹簧 Spring	0.02	TH-4/5
06 配气杆 Rigid Valve	1.72	WK-PQG-56
07 O型圈 O-Ring	0.01	O-PQG-56
08 内缸 Internal Cylinder	2.70	WK-NG-56
09 活塞 Piston	13.4	WK-HS-56
10 外套管 Piston Case	18.4	WK-WTG-56
11 导向套 Guide Sleeve	2.50	WK-DXT-56
12 卡环 Bit Retainer Ring	1.00	WK-KH-56
13 前接头 Driver Sub	6.00	WK-QJT-56
密封件 Seal Kit	0.02	SK-56
02 × 1		
07 × 1		
易耗件 Consumable	34.41	CSB-56
01 × 1		
10 × 1		
13 × 1		
密封件 Seal Kit		

钻头尾柄 Bit shank
Wooke56®

钻头直径 Bit dia
140; 146; 148; 152

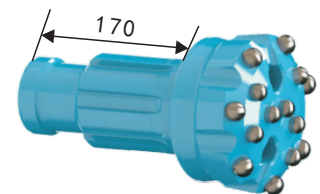

八花键 8 splines

重量Weight (kg)	外径Outside diameter (mm)	冲击器有效长度Hammer length without bit (mm)		
61	126	808		
钻孔范围Hole Range	适用气压Work Pressure	耗气量Air consumption, m ³ /min		
mm	bar	10bar	18bar	24bar
Φ140-Φ152	10-25	6	12.5	16.5

“*” 表示选配螺纹 (“*” Optional Thread type)

威猛快冲Wooke66®

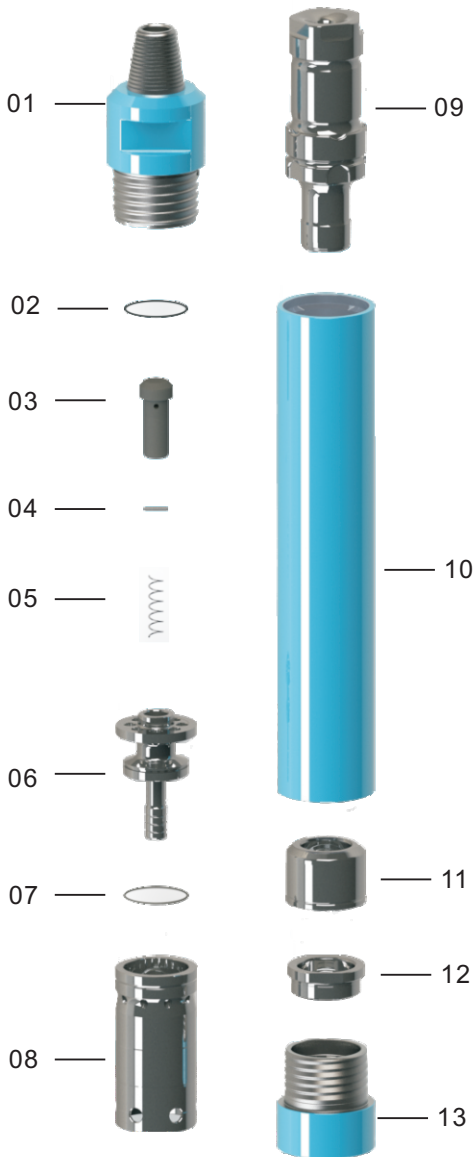

部件Replacement Parts	单重Weight(kg)	件号Part No.
01 后接头 Top Sub:3 $\frac{1}{2}$ "API REG	18.9	WK-HJT-66
02 O型圈 O-Ring	0.01	O-HJT-66
03 逆止阀 Check Valve Dart	0.8	TND-NZF-6/8
04 调气塞 Choke Blank (备选) (Optional)	0.01	TND-TQS-6/8
05 弹簧 Spring	0.05	TH-6/8
06 配气杆 Rigid Valve	3.73	WK-PQG-66
07 O型圈 O-Ring	0.01	O-PQG-66
08 内缸 Internal Cylinder	4.37	WK-NG-66
09 活塞 Piston	13.4	WK-HS-66
10 外套管 Piston Case	25.2	WK-WTG-66
11 导向套 Guide Sleeve	3.55	WK-DXT-66
12 卡环 Bit Retainer Ring	1.41	WK-KH-66
13 前接头 Driver Sub	7.75	WK-QJT-66
密封件 Seal Kit	0.02	SK-66
02 × 1		
07 × 1		
易耗件 Consumable	51.86	CSB-66
01 × 1		
10 × 1		
13 × 1		
密封件 Seal Kit		

钻头尾柄 Bit shank
Wooke66®

钻头直径 Bit dia
159;165;178

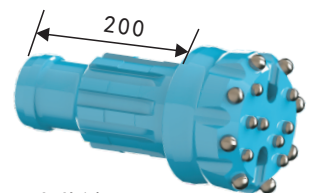

十花键 10 splines

重量Weight (kg)	外径Outside diameter (mm)	冲击器有效长度Hammer length without bit (mm)		
96	148	946		
钻孔范围Hole Range	适用气压Work Pressure	耗气量Air consumption, m ³ /min		
mm	bar	10bar	18bar	24bar
φ 159-φ 178	10-30	7	16	23.5

无尾管中高气压潜孔冲击器

Medium High Air Pressure DTH Hammers

wooke
ROCK DRILL EQUIPMENT
五环欧科

威猛快冲Wooke86®

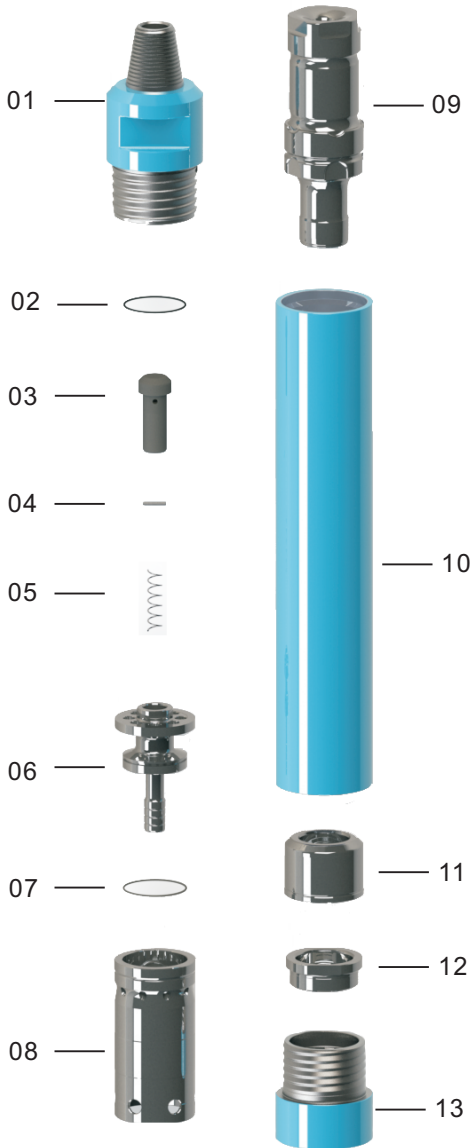

部件Replacement Parts	单重Weight(kg)	件号Part No.
01 后接头 Top Sub:4½"API REG	40.48	WK-HJT-86
02 O型圈 O-Ring	0.01	O-HJT-86
03 逆止阀 Check Valve Dart	0.8	TND-NZF-6/8
04 调气塞 Choke Blank (备选) (Optional)	0.01	TND-TQS-6/8
05 弹簧 Spring	0.05	TH-6/8
06 配气杆 Rigid Valve	6.72	WK-PQG-86
07 O型圈 O-Ring	0.01	O-PQG-86
08 内缸 Internal Cylinder	8.05	WK-NG-86
09 活塞 Piston	44.5	WK-HS-86
10 外套管 Piston Case	50	WK-WTG-86
11 导向套 Guide Sleeve	4.57	WK-DXT-86
12 卡环 Bit Retainer Ring	1.41	WK-KH-86
13 前接头 Driver Sub	13.4	WK-QJT-86
密封件 Seal Kit	0.02	SK-86
02 × 1		
07 × 1		
易耗件 Consumable	103.89	CSB-86
01 × 1		
10 × 1		
13 × 1		
密封件 Seal Kit		

钻头尾柄 Bit shank
Wooke86®

钻头直径 Bit dia
203;216;219;222;230;245

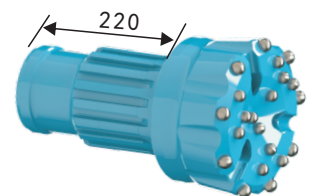

十六花键 16 splines

重量Weight (kg)	外径Outside diameter (mm)	冲击器有效长度Hammer length without bit (mm)		
170	184	1132		
钻孔范围Hole Range	适用气压Work Pressure	耗气量Air consumption, m ³ /min		
mm	bar	10bar	18bar	24bar
Φ203-Φ245	14-35	9	20	26

威猛快冲Wooke100®

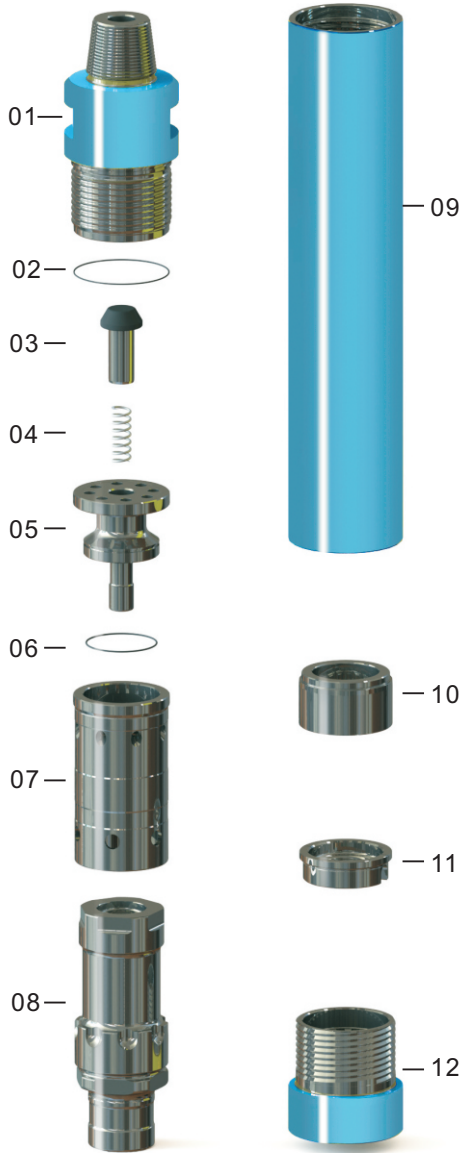

部件Replacement Parts	单重Weight(kg)	件号Part No.
01 后接头 Top Sub:5 $\frac{1}{2}$ "API REG	71.88	WK-HJT-100
02 O型圈 O-Ring	0.01	O-HJT-100
03 逆止阀 Check Valve Dart	0.9	WK-NZF-100
04 弹簧 Spring	0.05	TH-100
05 配气杆 Rigid Valve	13.12	WK-PQG-100
06 O型圈 O-Ring	0.01	O-PQG-100
07 内缸 Internal Cylinder	13.12	WK-NG-100
08 活塞 Piston	61.46	WK-HS-100
09 外套管 Piston Case	90.05	WK-WTG-100
10 导向套 Guide Sleeve	8.69	WK-DXT-100
11 卡环 Bit Retainer Ring	3.08	WK-KH-100
12 前接头 Driver Sub	21.53	WK-QJT-100
密封件 Seal Kit	0.02	SK-100
02 × 1		
06 × 1		
易耗件 Consumable	183.48	CSB-100
01 × 1		
09 × 1		
12 × 1		
密封件 Seal Kit		

钻头尾柄 Bit shank
Wooke100®

钻头直径 Bit dia
240; 245; 275; 305

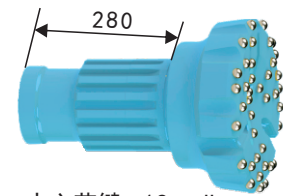

十六花键 16 splines

重量Weight (kg)	外径Outside diameter (mm)	冲击器有效长度Hammer length without bit (mm)		
284	220	1280		
钻孔范围Hole Range	适用气压Work Pressure	耗气量Air consumption, m ³ /min		
mm	bar	10bar	18bar	24bar
Φ240-Φ311	17-35	18	38	64



宜昌市五环钻机具有限责任公司

地址：湖北省宜昌市伍家岗工业园
邮编：443000
电话：0717-6343890
传真：0717-6262008
邮箱：info@wookechina.com
网址：www.wookechina.com

WOOKE ROCK DRILL EQUIPMENT CO.,LTD

ADD:Wujiagang Industrial Zone,Yichang,Hubei,China
Tel:+86-717-6343815 / 6262131
Fax:+86-717-6262118
E-mail:info@wooke-intl.com
MSN:wooke-intl@hotmail.com
Http://www.wooke-intl.com